

FLAMPOULE

Samuel Aden & Martin De Bie

Matérialisation de la musique par la lumière.

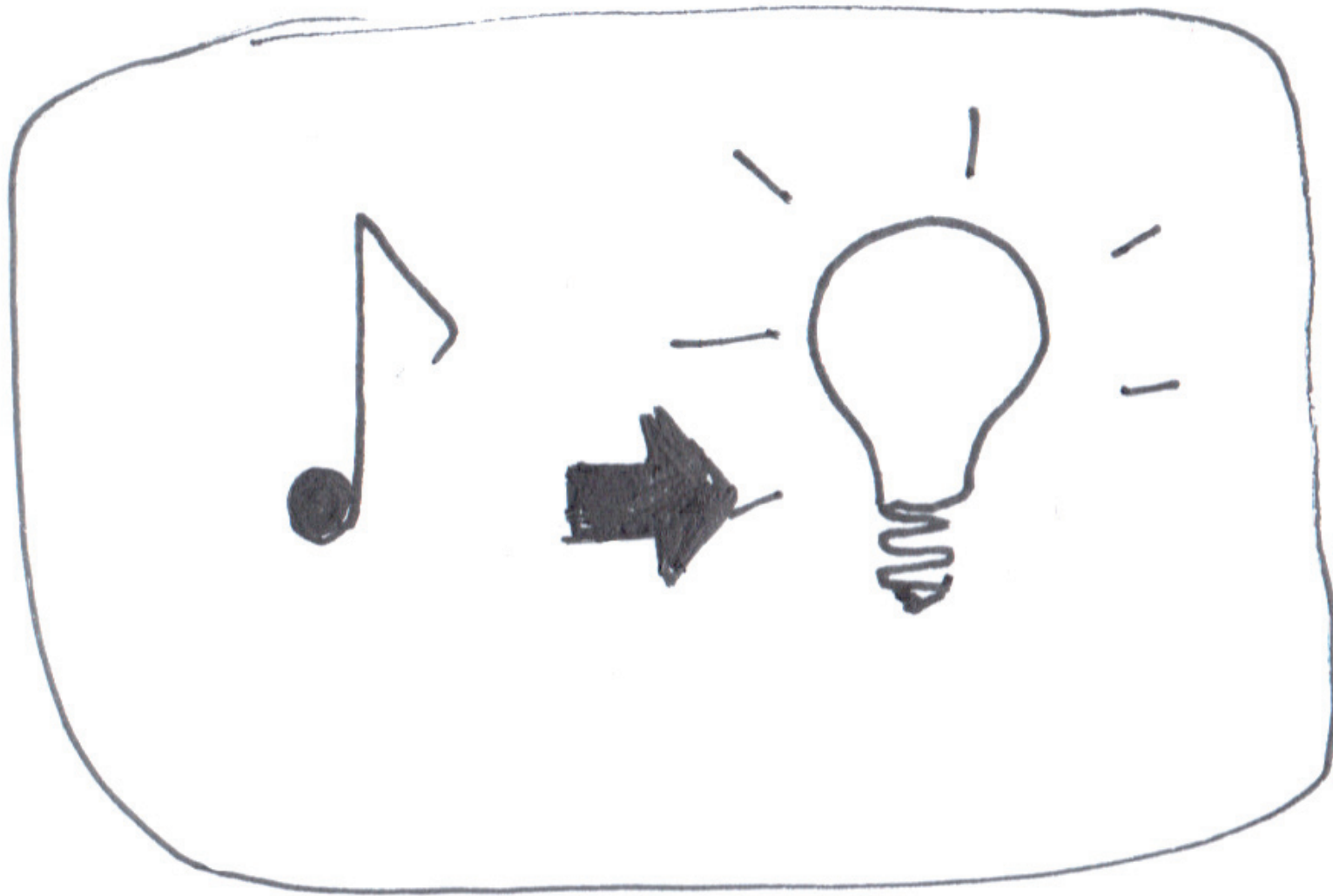

Création d'instruments sourds.

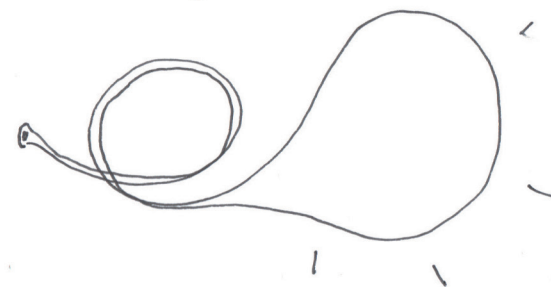
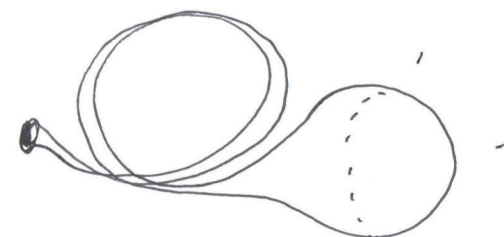
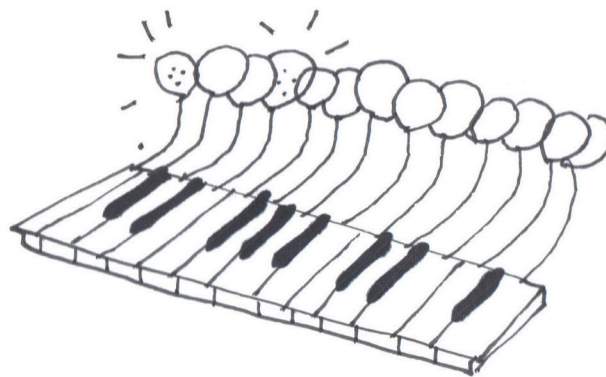
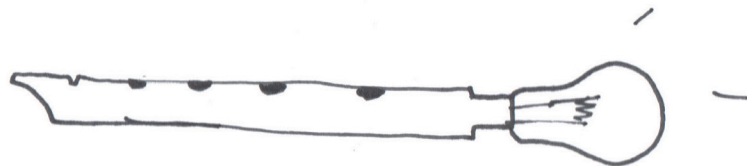

Brainstorming.



Orchestre hybride.



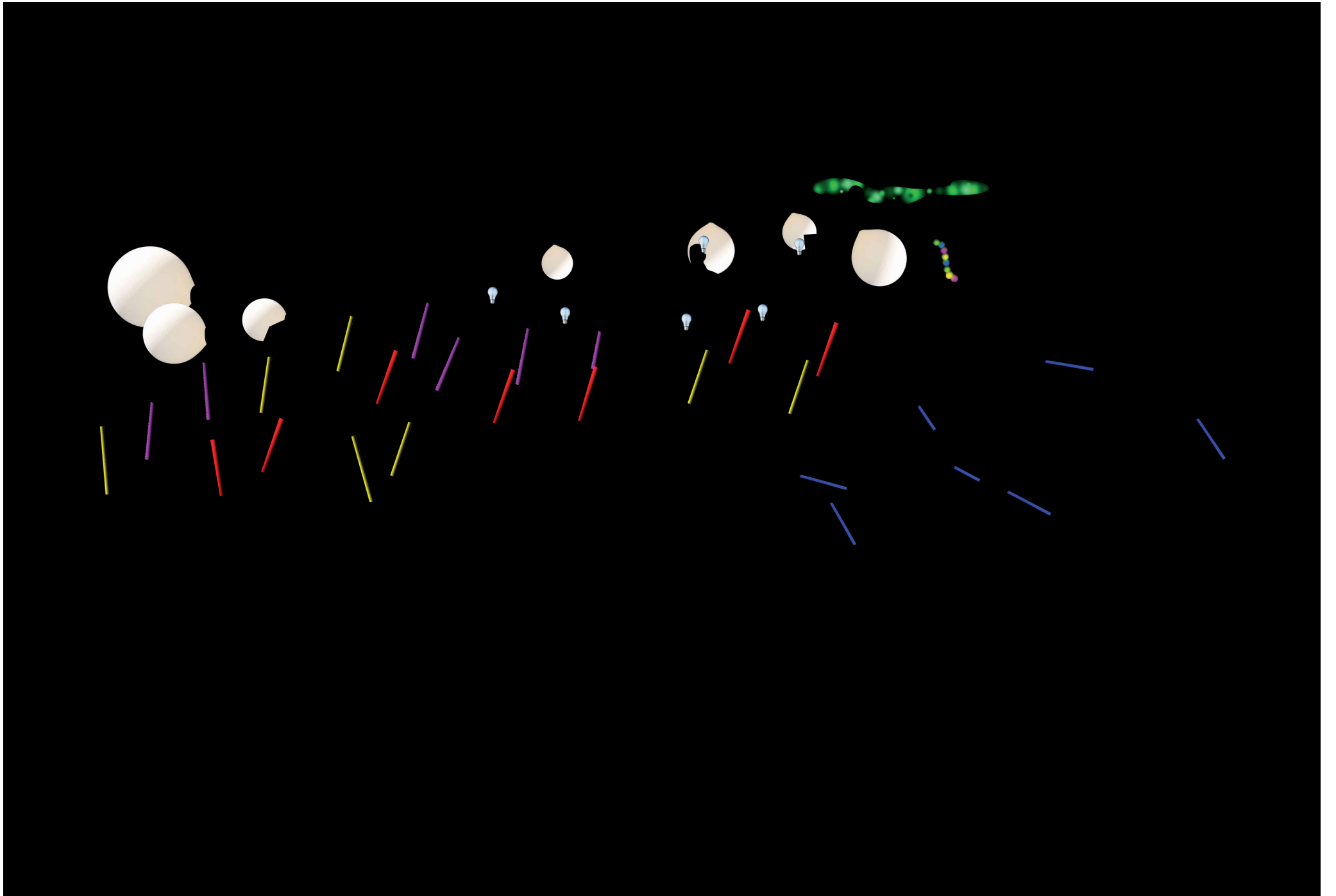

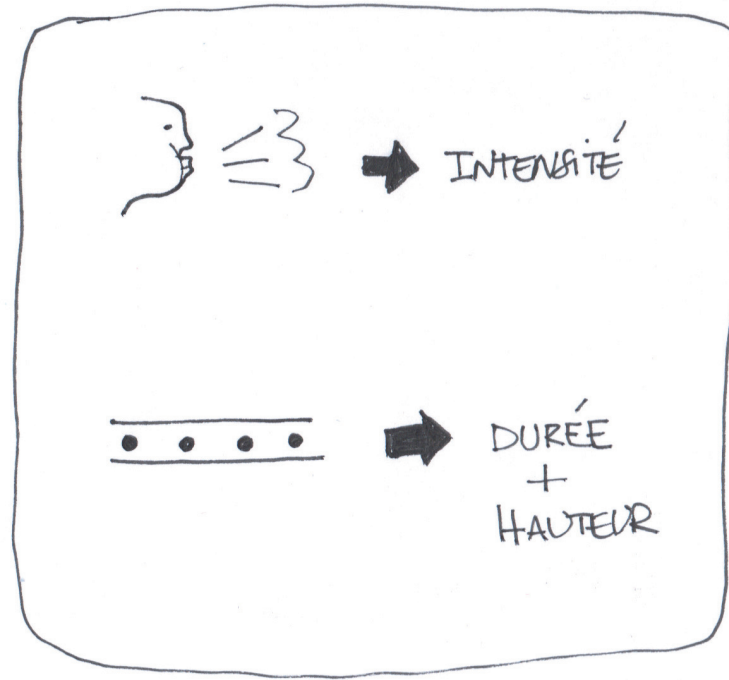

Objet développé.

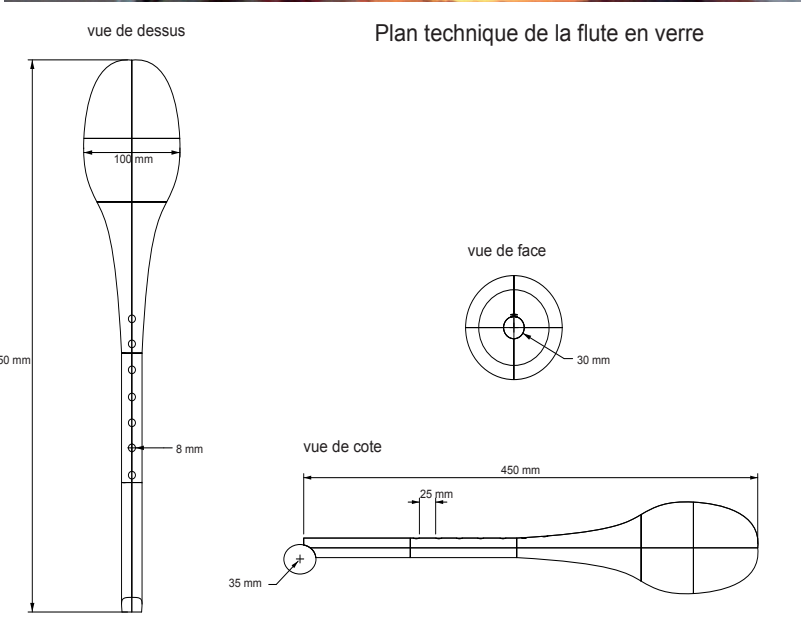
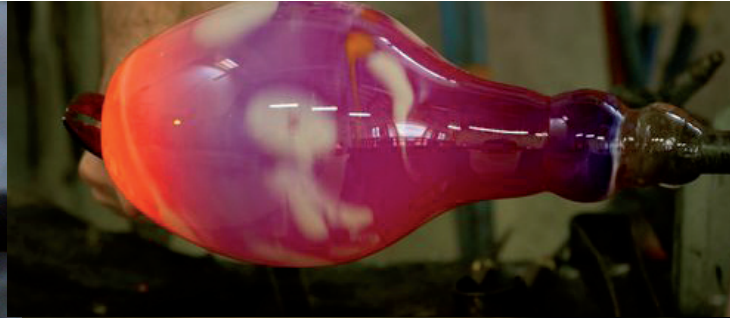
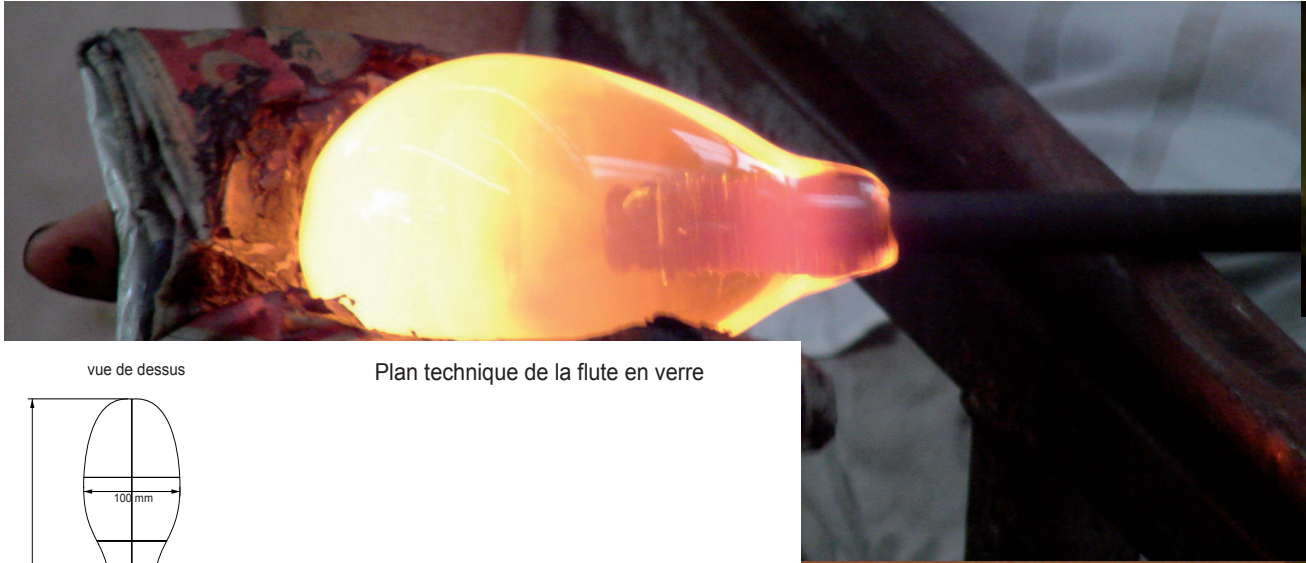

Mise en oeuvre.



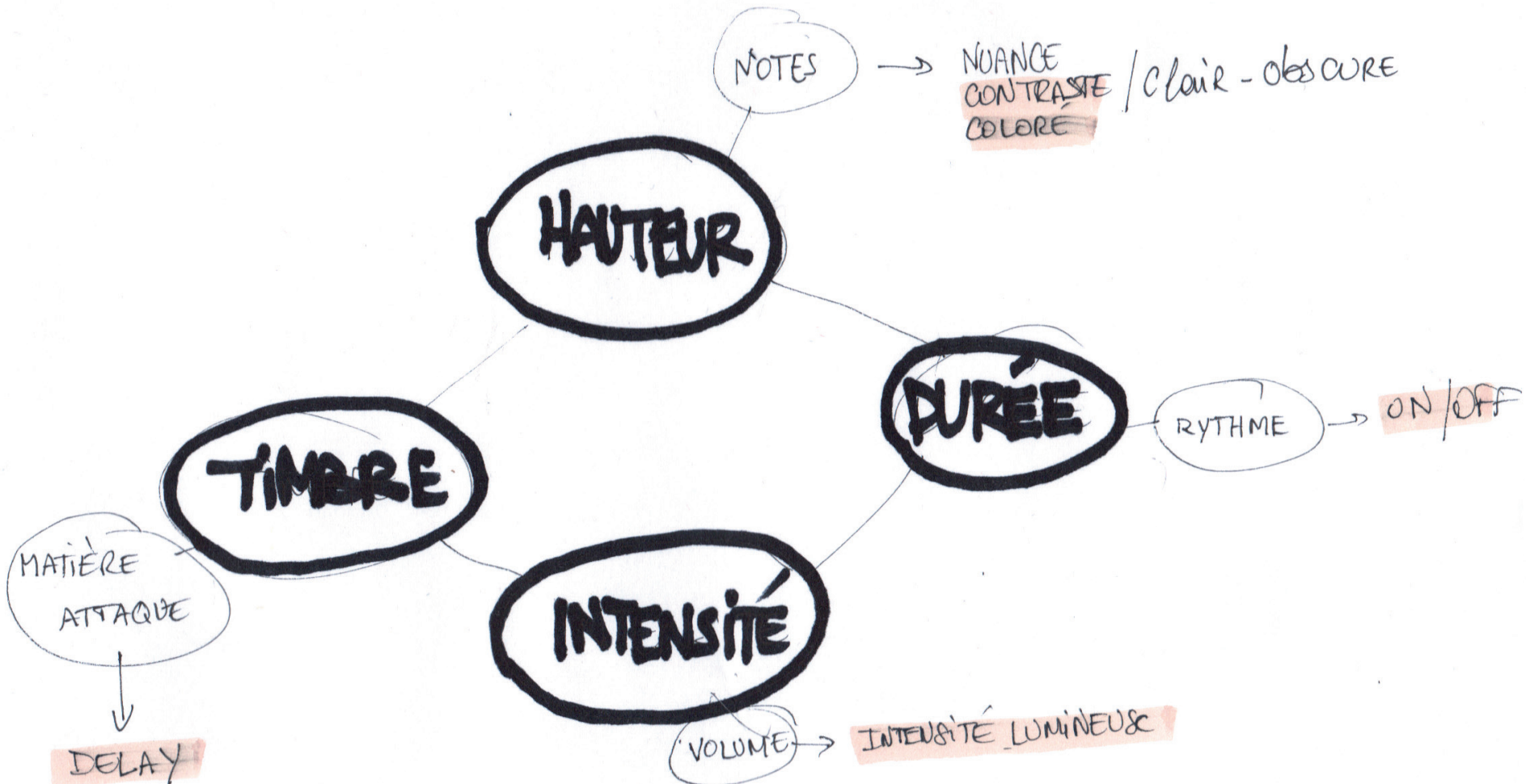

DO	RÉ	MI	FA	SOL	LA	SI	DO
●	●	●	●	●	●	●	●
●	●	●	●	●	●	●	○
●	●	●	●	●	●	○	●
●	●	●	●	●	○	○	○
●	●	●	●	○	○	○	○
●	●	●	○	○	○	○	○
●	○	○	●	○	○	○	○
●	○	○	●	○	○	○	○

Partition notes colorées.

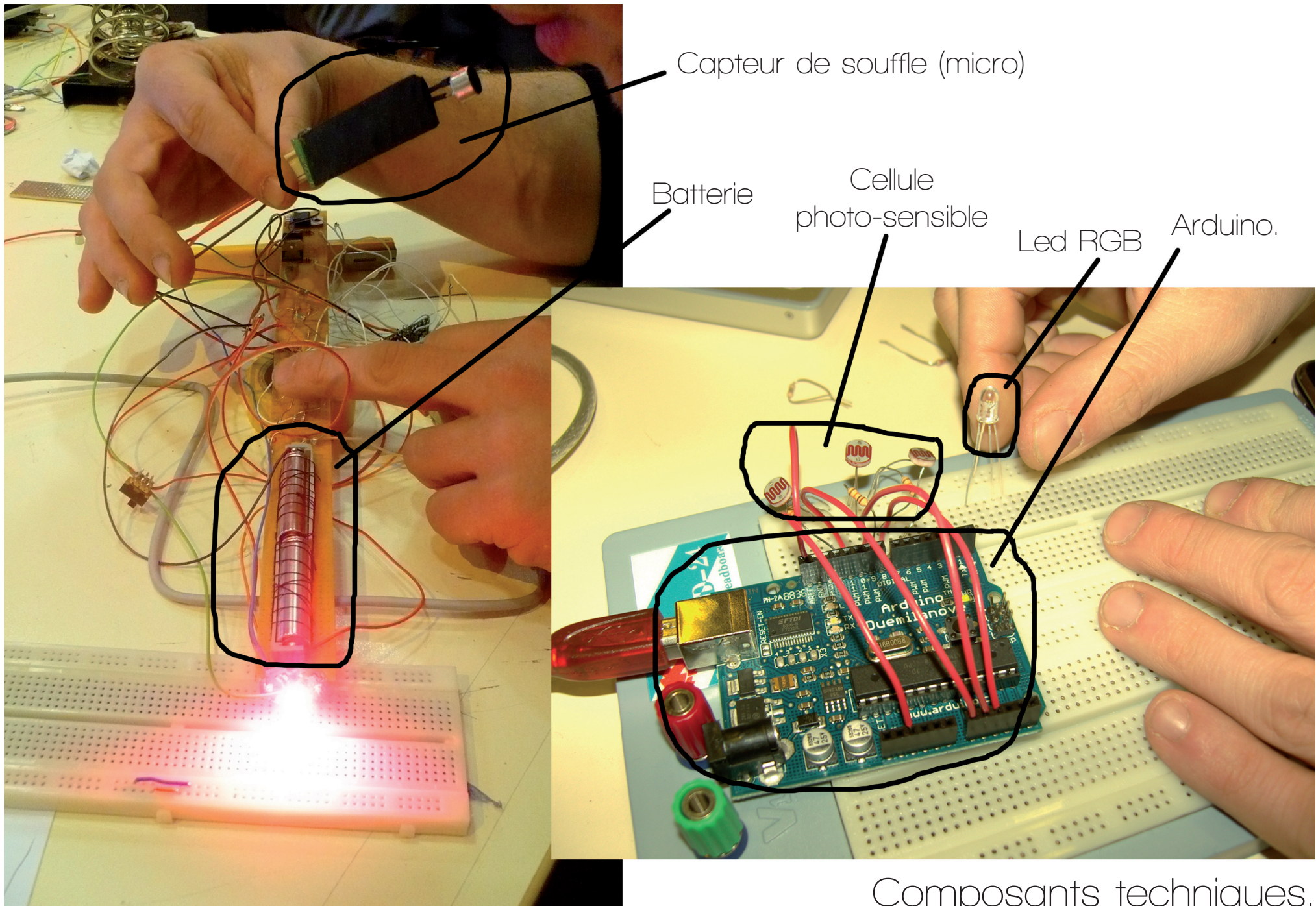

Capteur de souffle (micro)

Batterie

Cellule  
photo-sensible

Led RGB

Arduino.

Composants techniques.



# Projet «Flampoule».

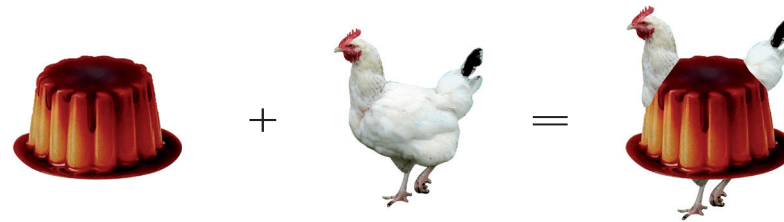

Samuel Aden  
*adensamuel@yahoo.fr*

Martin De Bie  
*debiemartin@gmail.com*